

Installation instructions for Front Skid Plate suitable for JEEP Wrangler JK (2007-2017) Guard Protection Spare Parts

Code SPJEWJK

---

1. Install the six M8 U-nuts onto the Bumper edge (Fig 1) aligning with the six holes in the Bumper

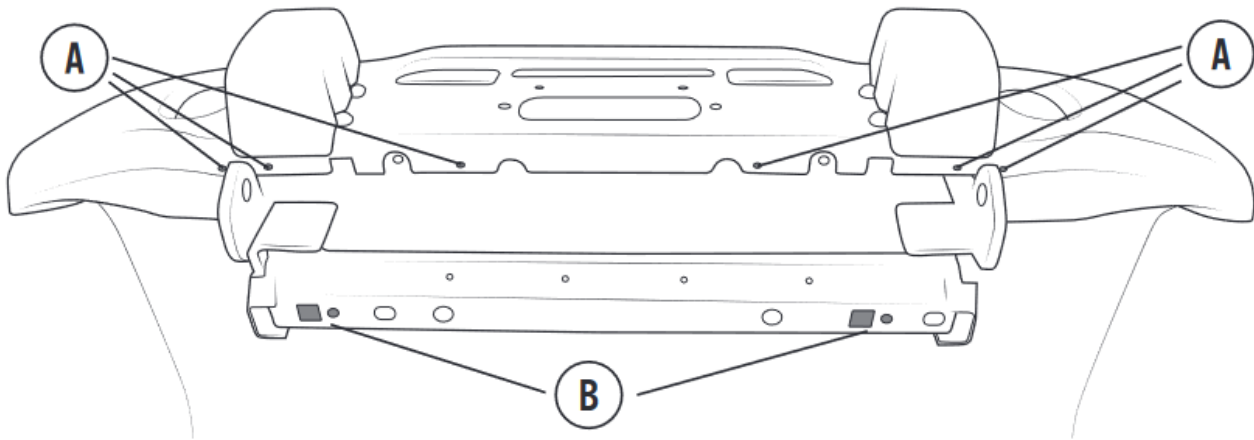

Figure 1

Installation instructions for Front Skid Plate suitable for JEEP Wrangler JK (2007-2017) Guard Protection Spare Parts

Code SPJEWJK

2. Inspect your vehicles compatibility beam (Fig 2). Depending on the model year of your vehicle, your compatibility beam may have the square cut-outs (A), have only the round bolt holes (B), or no attachment holes at all. If NO holes are present skip to step #4

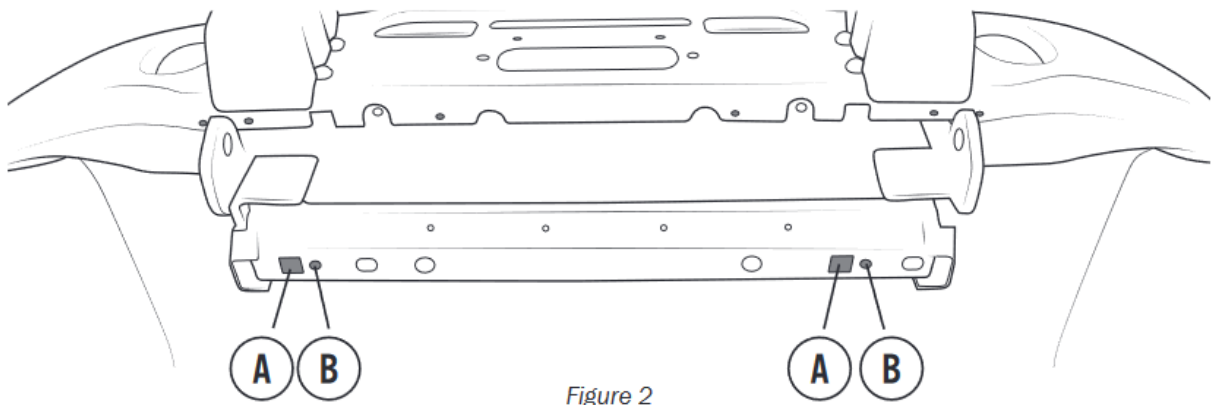

Figure 2

3. Install the two M10 U-nuts into the square cut-outs on the compatibility beam (Fig 1-B), aligning with the adjacent round holes. If the square cut-outs are not present on your vehicle you may skip this step. Continue to step #8
4. Hold the Skid Plate in position under the Bumper.
5. Using two M8 bolts, attach the Skid Plate to the Front Bumper at the outer-most holes.
6. Hold the rear of the Skid Plate tightly against the compatibility beam, mark the two rear mounting locations and center punch.

Installation instructions for Front Skid Plate suitable for JEEP Wrangler JK (2007-2017) Guard Protection Spare Parts

Code SPJEWJK

---

7. Remove the Skid Plate and drill two 13mm holes at the locations marked in step 6. De-burr the holes and apply rust inhibitor to all bare edges.
8. Position the Skid Plate for attachment.
9. Install the six M8 washer head bolts into the Front Bumper. Torque to 16 ft/lbs.
10. Install the two M10 washer head bolts into the compatibility beam, securing with either the M10
11. U-nuts (if installed in step 3) or the provided M10 flange nuts. Torque to 36 ft/lbs.

